

# SOLID STATE SOCKET METER (INOVONICS)

MODEL SKM-200i

## KEY BENEFITS

- Inovonics Transmitter
- Simple field Programming
- TAPWATCH 3 Compatible
- No Internal Battery
- ANSI C12 Accuracy

## SOCKET METER WITH TRANSMITTER AND INTERNAL CT(s)



## DESCRIPTION

The SKM-200i provides remote billing companies with a reliable and economical solid-state electric meter platform that smoothly incorporates the Inovonics technology and easily interfaces to the TAPWATCH 3 system, and also supports water and gas metering.

## SPECIFICATIONS

### FEATURES:

#### SIMPLE, PLUG-IN INSTALLATION

Pre-wired and configured to minimize installation labor.

#### LINE-POWERED

No batteries to service or replace.

#### NONVOLATILE MEMORY

Stable data storage through multiple events.

#### MULTIPLE CONFIGURATIONS

Forms 2S and 12S plug-in

#### GENERAL

Active Energy "kWh-only" meter

Designed for 20+ years life (1 year warranty)

Meets ANSI standards for performance

6-digit LCD

### APPLICABLE STANDARDS:

ANSI C12.1 for electric meters

ANSI C12.10 for physical aspects of Watthour meters

ANSI C12.19 Utility Industry End Device Data Tables

ANSI C12.20 for electricity meters, 0.2 & 0.5 classes

Operating Temperature.....-40°C to +85°C under cover

Nominal Voltage ..... 120Vac or 240Vac

Operating Voltage.....80% to 115% of Vn

Frequency..... 60Hz, ±5%

Relative Humidity..... 5% to 95%, non-condensing

Starting Load (Watts)..... Class 200, 0.050Aac (12W)

Load Performance Accuracy ... Class 0.5%, 0.2% typical

Available Forms..... 2S, 12S

**DIMENSIONS OF SOCKET METER 2S**

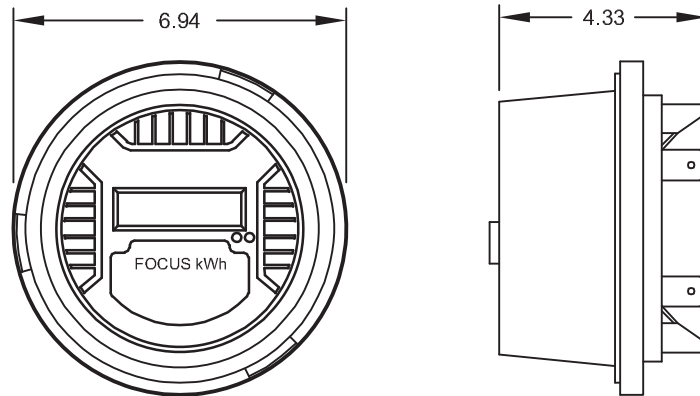

**ALL DIMENSIONS IN INCHES.  
TOLERANCE: ±0.03 INCHES.**

Dwg# 0902-00979-B Rev B

**DIMENSIONS OF SOCKET METER 12S**

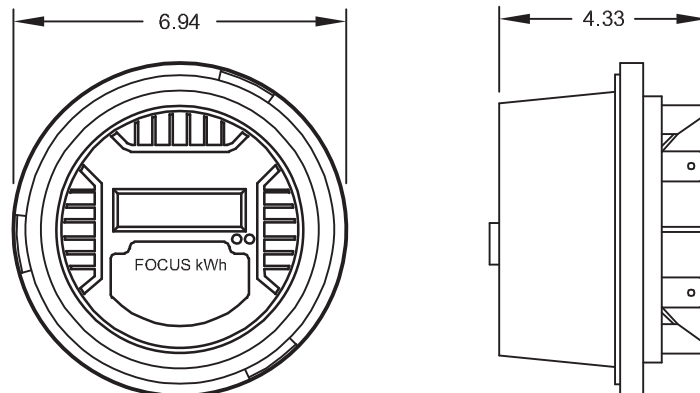

**ALL DIMENSIONS IN INCHES.  
TOLERANCE: ±0.03 INCHES.**

Dwg# 0902-00979-B Rev B